

Disk Rock Cutting Tool for the Implementation of Resource-Saving Technologies of Mining of Solid Minerals

*Leonid Mametyev*¹, *Aleksey Khoreshok*¹, *Alexander Tsekhin*¹, and *Andrey Borisov*^{1*}

¹ T.F. Gorbachev Kuzbass State Technical University, 650000, 28 Vesennaya St., Kemerovo, Russia

Abstract. The directions of a resource and energy saving when creating a boom-type effectors of roadheaders of selective action with disc rock cutting tools on a multi-faceted prisms for the destruction of formation of minerals and rocks pricemax are presented. Justified reversing the modes of the crowns and booms to improve the efficiency of mining works. Parameters of destruction of coal and rock faces by the disk tool of a biconical design with the unified fastening knots to many-sided prisms on effectors of extraction mining machines are determined. Parameters of tension of the interfaced elements of knots of fastening of the disk tool at static interaction with the destroyed face of rocks are set. The technical solutions containing the constructive and kinematic communications realizing counter and reverse mode of rotation of two radial crowns with the disk tool on trihedral prisms and cases of booms with the disk tool on tetrahedral prisms in internal space between two axial crowns with the cutter are proposed. Reserves of expansion of the front of loading outside a table of a feeder of the roadheader of selective action, including side zones in which loading corridors by blades of trihedral prisms in internal space between two radial crowns are created are revealed.

1 Introduction

In leading mining countries, the main means of mechanization of mining operations are roadheaders, shearers, plough system and drilling machines. Improvement of the effectors of roadheaders boom type by rational combination and the allocation of cutter and disk tool for the implementation of the principle of the destruction of coal and strong rocks major cleavage to resource and energy conservation is a topical scientific and technical problem.

2 Materials and methods

Modern mining machines is implemented by mechanical destruction method of coal and rock faces using the broad structural spectrum of mining tools. It is known that the destruction of rocks by cutting is an energetically favorable process [1]. However, in the abrasive rocks of medium and above medium strength, this method is not practically acceptable, in connection

* Corresponding author: borisovau@kuzstu.ru

with the intensive wear of the working tool, due to the inability to transfer a large power unit is required for destruction of the face. Therefore, the area of effective application of the destruction of rocks by cutting is limited to breed with a little abrasiveness (less than 15 mg) with a limit of compressive strength up to 60 MPa.

Studies in KuzSTU justified by the prospects of using the disk tools on the effectors of mining machines.

Working conditions mining tool for boom-type roadheaders necessitates the identification of functional possibilities of using the disk tools on the crown effectors.

The complex of requirements to the construction of the crowns boom-type roadheaders selective action is based on the interdependence of kinematic, power and design parameters of the attachment disc tool with the physico-mechanical properties and fracture parameters of faces and the provision of installation and dismantling operations.

To enhance the functionality of the effectors of roadheaders selective action via combining the processes of destruction, loading and crushing of rock mass proposed disk tools with the attachment to the triangular prisms in the construction of two reversible radial longitudinal axis of the crowns (fig. 1) [2].

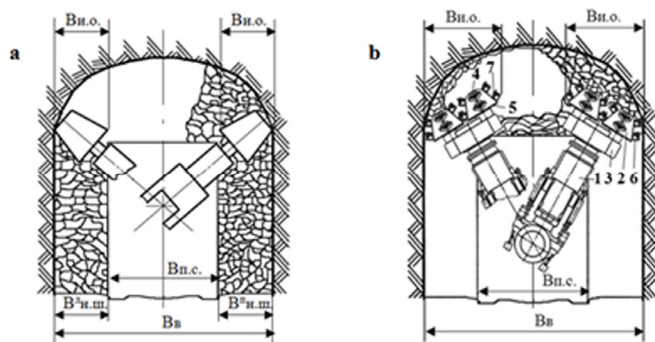

Fig. 1. Work boom-type effector with the radial crowns: a – prior to modernization; b – after modernization.

The effector of roadheader (fig. 1, b) contains an boom 1, which has two destructive loading of the crowns 2, kinematically connected through the transfer case gear 3. Each crown 2 consists of truncated cones or prisms with a small base 4 and a big base 5, a hub which is attached to the output shaft of the gearbox 3. To the outer surfaces of crowns attached triangular prism 6 with disc tools 7. Gear kinematic connection allows the triangular prisms 6 crowns 2 during rotation to create a spatial mazes and corridors, providing combination of the processes of destruction, crushing and loading within the project of the width B_B of the driven working. The process of loading zones in the cut off parts of tunnel production is characterized by the following parameters: $B_{н.о.}$ – working width of the effector along the sides; $B_{н.ш.}$ и $B_{н.ш.}^n$ – width is not shipped stacks of destruction products from the left and right sides; B_B – width of project development; $B_{п.с.}$ – the width of the delivery table of the feeder of the loading device, characterizing the width of the zone of the front loading.

The department of mining machines and complexes KuzSTU in cooperation with the department of mining equipment of YUTI (branch) of Tomsk Polytechnic University conducted studies of the stress-strain state of various designs of the cantilever attachment disk tool by the finite element method. One of the results of the study of the stress state of the mounting disk tool to a triangular prism with the nut shown in fig. 2 [2].

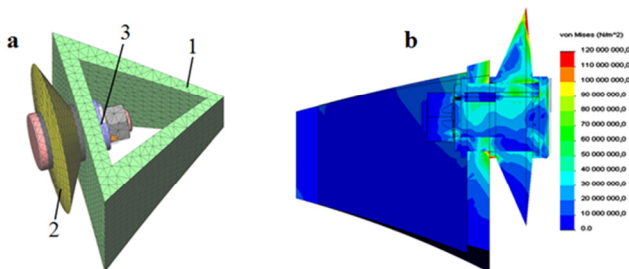

Fig. 2. Finite element model (a) and stress state (b) option of the mount of the disk tool are: 1 – triangular prism; 2 – disc; 3 – nut.

In three constructive variants of the attachment (strap, screw and nut) used biconical and conical disk tools. As an example, in fig. 2, b shows the distributions of the equivalent stress according to Mises for disk tool diameter $D = 0,16$ m.

The console variants of the attachment of the disk tool on the triangular prisms taking into account the results of modeling the stress-strain state in the destruction of coal and rock faces are recommended to equip their working bodies roadheaders, shearers and drilling machines.

The main disadvantage of many of the effectors of roadheaders cross-axial design is the low productivity of the process of the cutting to the presence of an indestructible block coal and rock faces in the space between the crowns (fig. 3) [3].

The department of mining machines and complexes KuzSTU to improve the efficiency of the process of the cutting of the effector roadheader of selective action with cross-axial crowns separated from each other by the casing of the distributing reducer proposed in the space between the crowns to place the disk tools on tetrahedral prisms.

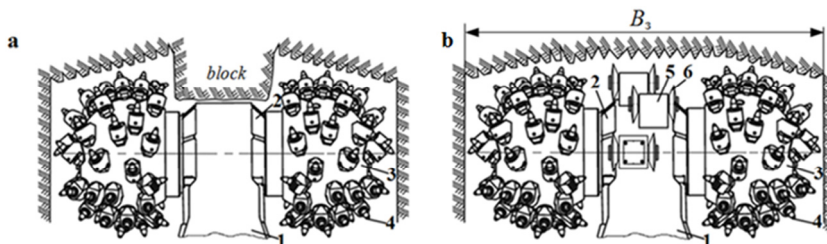

Fig. 3. Cutting effectors: a – analog; b – upgraded

In the process of the cutting (fig. 3) boom 1 the effector with the distributing gearbox 2, axial crowns 3, cutters 4, tetrahedral prisms 5 with disc tools 6 make a vertically rotatable planing motion with simultaneous telescopic effect on the face. In this block (fig. 3, a), which is formed by the standard of the effectors-analogues is destroyed in the space between the crowns of disk tools 6 on the tetrahedral prism 5 (fig. 3, b). Part of the body of the distributing gearbox 2 boom 1 turned to face and made in the form of a cylindrical sector, on the outer surface of which are mounted in a staggered tetrahedral prism 5 with the disk tools 6, fitting into the space gap between lines of cut formed by the outermost cutters 4 of side large grounds axial crowns 3. Thus the radial departure of V-cutting edges of the tool disk 6 does not exceed the radial departure of the extreme cutters 4 on large grounds axial crowns 3. It allows to be effectively cut to the width B_3 (fig. 3, b) due to movement of the boom 1 during the cutting in the vertical plane with a telescopic effect. In the case of step processing slaughtering axial crowns 3 is carried out the turning movement of the boom 1 in a horizontal plane to the right or left sides of the excavation.

Similarly, a procedure for the construction of finite element models and calculation efforts loadings P_z, P_y, P_x , disc tool with the attachment on tetrahedral prisms. In fig. 4, a finite element model of a tetrahedral prism with disc tools creating an additional fracture zone in the space

between the crowns effector of roadheader. For the initial conditions to calculate the parameters of the stress state was chosen ranges of the characteristics of the destructible faces: coal ($\sigma_{\text{сжк}} = 12,4; 13,5; 14,8$ MPa) and the rock ($\sigma_{\text{сжк}} = 51; 60,6; 78,9$ MPa). In the simulation used four possible designs of disk tool diameter $D = 0,16$ m (three biconical with pointed angles: $\varphi = \varphi_1 + \varphi_2 = 25^\circ + 5^\circ = 30^\circ; 20^\circ + 10^\circ = 30^\circ; 15^\circ + 15^\circ = 30^\circ$ and one conic $\varphi = 30^\circ$) [3].

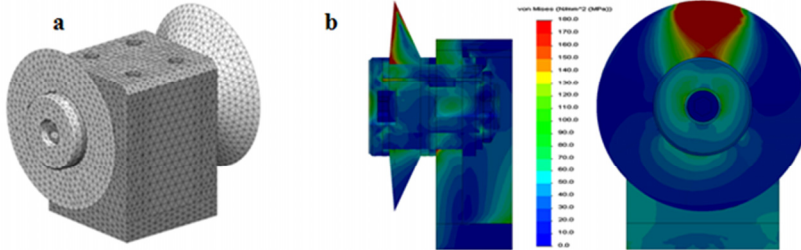

Fig. 4. Finite element model (a) and stress state (b) option of the mount separate disks ($\varphi = 25^\circ + 5^\circ = 30^\circ$) to the tetrahedral prism in the destruction of the rock mass $\sigma_{\text{сжк}} = 78,9$ MPa.

The calculation was performed in SolidWorks Simulation. Meshing was used parabolic finite elements in the form of tetrahedra. The size of the finite elements was chosen so that further increase in mesh density had no significant effect on the results of the calculations. Material details 35HGSA, steel 45. The cutting force P_z , penetration P_y and lateral force P_x on the disc tools are subject to design, operating parameters and characteristics of the destroyed face $\sigma_{\text{сжк}}$. Computational effort of loading P_z, P_y, P_x was applied to finite element models (fig. 4, a) disk tools the attachment in tetrahedral prisms to produce pictures of the stress-strain state for biconical and conical disc tools (fig. 4, b).

On the basis of the analysis of the basic constructive solutions [4-13] proposed the original technical solution, which includes tetrahedral prisms with dual disk tools (fig. 5), made as a single prefabricated structural unit with the joint possibility of free rotation relative to the fixed axle-bushings. Its implementation provides for joint rotation of the two disc tools on each tetrahedral prism with a decrease in the process of jamming and wear in the cut of the boom-type effector of roadheader in the massif [4].

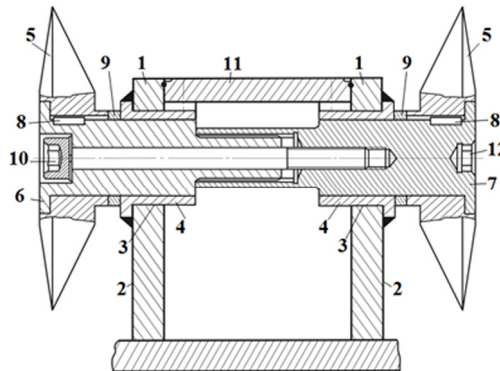

Fig. 5. Design tetrahedral prism with dual disk tools.

Tetrahedral prism 1 (fig. 5) consists of two working faces 2 with a through cylindrical holes 3 and two side faces. Inside each of the through cylindrical holes 3 is placed the axle-bushing 4. While paired disk tools 5 made as a single dismounted and mounted structural unit with the possibility of a joint free rotation about fixed axle-bushing 4. Each axle-bushing 4 consists of an end thrust collar rigidly attached to the outer surface of the working faces 2 tetrahedral prism 1 and the cylindrical surface of the console placed in a through cylindrical hole 3 of the working

face 2 in the internal space of the tetrahedral prism 1.

A single dismounted and mounted constructional unit made in the form rigidly attached to each other two axes 6, 7 from the with thrust ribs, one of which contains a slotted shank, and the other contains the spline hub. Axis 6, 7 have the zones providing connection of the disk tool 5 by means of dowel-pawl 8. Remote face of the washer 9 is placed between the end faces of each of the two disc tools 6 and the end faces of the thrust ribs of each of the two axle-bushings 4. The axle 6 is formed with a stepped through hole, inside which is placed remote the screw 10 for fastening a single dismounted and mounted structural unit. For protection of internal space of a tetrahedral prism 1 use a tetrahedral cover 11. From the free end of the axle 7 is made hexagonal recess 12 under the key for the implementation of installation and dismantling operations.

3 Results and discussion

Found that equivalent stress according to Mises all versions of the attachment disk tool radial crowns roadheaders is substantially below the yield strength for steel 35HGSA ($\sigma_T = 490$ MPa). With the transition from asymmetry to symmetry biconical disk tools can be traced to the reduction zone settings equivalent stresses in the attachment points with the general increase in maximum stress with the increase of rock strength in a wide range $\sigma_{\text{сж}} = 50-120$ MPa.

It is revealed that, disk tools conical ($\varphi = 30^\circ$) and biconical performances ($\varphi = 25^\circ+5^\circ = 30^\circ$) implement the process of breaking larger areas of maximum equivalent stresses and displacements than alternatives biconical version ($\varphi = 20^\circ+10^\circ = 30^\circ$ and $\varphi = 15^\circ+15^\circ = 30^\circ$), and the minimum sizes of zones of equivalent stresses and displacements observed for the biconical design ($\varphi = 15^\circ+15^\circ = 30^\circ$).

Decrease in the sizes of zones of the maximum equivalent tension and movements on a bottomhole side of the trihedral prism turned to a face for option of knot of fastening of the disk tool by a nut, in comparison with fastening by the screw is noted that characterizes higher rigidity of fastening by a nut.

Technical solutions and test results were obtained within the base part of Ministry of Education and Science of Russia state order, project 632 "Investigation of technologies and techniques parameters for selecting and developing innovative designs to improve operating efficiency of multipurpose mining machines in Kuzbass".

4 Conclusion

1. One of the directions of energy saving in underground coal mining or mineral raw materials is to reduce the downtime of roadheaders and to increase the rate of penetration of preparatory workings by the extension of front loading before the cut off parts zones using the original boom-type effectors with two radial crowns and disk tool on the triangular prisms.

2. Proposed to reduce the energy intensity and time of cutting boom-type by the roadheaders of selective action using the disk tool in tetrahedral prisms in the inner space between the axial cutting units crowns.

3. Additional factors of resource-saving are to a significant increase in durability and service life of disc rock-destructive tools compared to cutters for reducing the cost of maintenance and repair in the face space.

References

1. A.A. Khoreshok, L.E. Mametev, A.Yu. Borisov, A.V. Vorobev, *Appl. Mech. Mater.* **770**, 429 (2015)

2. A.A. Khoreshok, L.E. Mametev, A.Yu. Borisov, A.V. Vorobev, *Applied Mechanics and Materials*, **770**, 434 (2015)
3. A.A. Khoreshok, L.E. Mametyev, A.Yu Borisov 2015 I Miner's Week – Reports Of The Xxiii International Scientific Symposium, 482 (2015)
4. B.L. Gerike, P.B. Gerike, V.I. Klishin, A.P. Filatov, *J. Min. Sci.* **44:5**, 497 (2008)
5. B.L. Gerike, P.B. Gerike, A.P. Filatov, V.I. Klishin, *J. Min. Sci.* **42:6**, 610 (2006)
6. P.B. Gerike, M.A. Belikov, *J. Min. Sci.* **39:2**, 162 (2003)
7. P.D. Krestovozdvizhensky, V.I. Klishin, S.M. Nikitenko, P.B. Gerike, *J. Min. Sci.* **51:2**, 323 (2015)
8. Y Zhang, X W Wang, H F Liu, *Appl. Mech. Mater.* **487**, 513 (2014)
9. K. Yang, Y. M. Xia, Y. S. Wu, *Appl. Mech. Mater.* **508**, 159 (2014)
10. A. N. Zhang, Z. F. Zhu, F. Zhu, *Adv. Mater. Res.* **791:793**, 742 (2013)
11. X H Li, W Du, Z L Huang, W L. Fu, *Appl. Mech. Mater.* **127**, 385 (2011)
12. G. Wittenberger, M. Cehlár, Z. Jurkasová, *Acta Montanistica Slovaca*, **17:4**, 241-246 (2012)

E3S Web of Conferences

Proceedings

The IInd International
Innovative Mining Symposium
(Devoted to Russian Federation
Year of Environment)

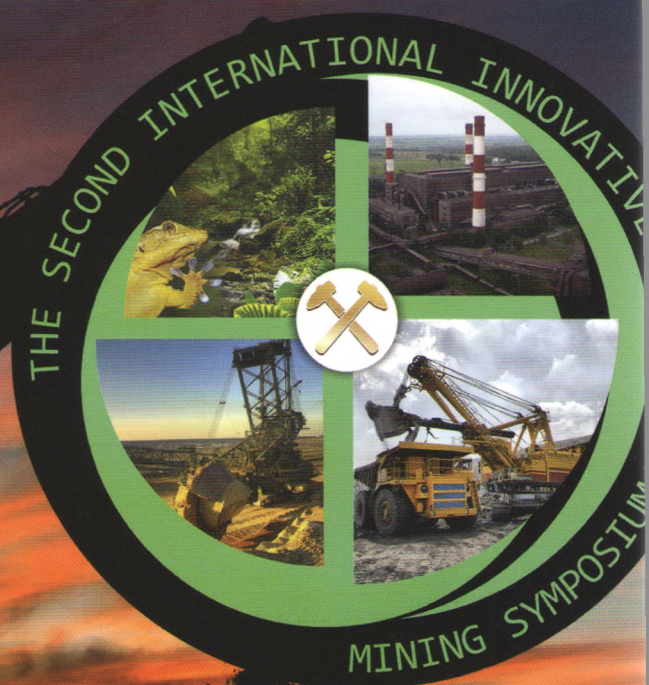

2017
THE YEAR OF ECOLOGY
IN RUSSIA

ENVIRONMENT, ENERGY &
EARTH SCIENCES

E3S Web of Conferences

**The Second International
Innovative Mining Symposium
(Devoted to Russian Federation Year of
Environment)**

Kemerovo, Russian Federation, November 20-22, 2017

Edited by:

M. Tyulenev, S. Zhironkin, A. Khoreshok, S. Voth,
M. Cehlár and D. Nuray

edp sciences

Contents

00001 Preface: Innovative Competencies of Mining engineers in Transition to the Sustainable Development

A. Krechetov, A. Khoreshok and V. Blumenstein

00002 Preface: From Mining Innovations to Sustainable Development: Keynote Speakers of the First to the Second International Innovative Mining Symposium

M. Cehlár, J. Janočko, N. Demirel, S. Anyona, S. Vöth, M. Tyulenev and S. Zhironkin

Environment Saving Mining Technologies

01001 Gas Hydrates of Coal Layers as a Methane Source in the Atmosphere and Mine Working

V. Dyrdin, S. Shepeleva and T. Kim

01002 The Mine Working's Roof Stress-strain State Research in the Perspective of Development of New Coal Deposits of Kuzbass

S. Kostyuk, N. Bedarev, O. Lyubimov and A. Shaikhislamov

01003 Carbon-Containing Waste of Coal Enterprises in Magnetic Sorbents Technology

E. Kvashevaya, E. Ushakova and A. Ushakov

01004 Predicting the Possibility for Deep Hydroprocessing of Some Kuzbass Coals

I. Petrov and B. Tryasunov

01005 Development and Substantiation of Parameters of Environmentally Friendly Technology for Filling the Vertical Mine Workings with Autoclaved Slag-Concrete

A. Uglyanitca and K. Solonin

01006 Rock Deformation Behavior Near Excavations Under the Influence of High Tectonic Stress in Coal Seam V-12, "Severnaya" Mine, JSC "Urgalugol"

P. Grechishkin, E. Razumov, O. Petrova, A. Kozlov and E. Aushev

01007 New Technical Solution for Vertical Shaft Equipping Using Steel Headframe of Multifunction Purpose

E. Kassikhina, V. Pershin and Y. Glazkov

01008 Research of the Quality of Quarry Dumpers Engine Crankshafts Sliding Bearings of Various Manufacturers

A. Korotkov, L. Korotkova and D. Vidin

01009 New Opportunities to Expand Information on Intense-Strained State of the Earth's Crust in the Areas of Development Mineral Resources During Monitoring Creation

V. Pershin and A. Solovitskiy

- 01010 The Extent of Destruction Zones Within Protective Pillars in Jsc “Suek-Kuzbass” Underground Mines
N. Pirieva and I. Ermakova
- 01011 Prerequisites for the Establishment of the Automated Monitoring System and Accounting of the Displacement of the Roof of Underground Mines for the Improvement of Safety of Mining Work
A. Abramovich, E. Pudov and E. Kuzin
- 01012 Increasing Stability of Mine Surface Facilities on the Fill-Up Ground
M. Sokolov and S. Prostov
- 01013 Logistic Principles Application for Managing the Extraction and Transportation of Solid Minerals
A. Tyurin
- 01014 Promising Technologies of Mining and Processing of Solid Minerals
S. Shabaev, S. Ivanov and E. Vakhianov
- 01015 Three-Dimensional Computer Simulation as an Important Competence Based Aspect of a Modern Mining Professional
O. Aksenova and A. Pachkina
- 01016 Unmanned Mine of the 21st Centuries
I. Semykina, A. Grigoryev, A. Gargayev and V. Zavyalov
- 01017 Determination of the Geometric Form of a Plane of a Tectonic Gap as the Inverse Ill-posed Problem of Mathematical Physics
D. Sirota and V. Ivanov
- 01018 Parameters of Solidifying Mixtures Transporting at Underground Ore Mining
V. Golik and Y. Dmitrak
- 01019 Drilling Rig Operation Mode Recognition by an Artificial Neuronet
F. Abu-Abed and N. Borisov
- 01020 Perspectives for application of moulded sorption materials based on peat and mineral compositions
O. Misnikov
- 01021 Technogenic Rock Dumps Physical Properties’ Prognosis via Results of the Structure Numerical Modeling
S. Markov, V. Martyanov, E. Preis and A. Abay
- 01022 Modeling of Energy-saving System of Conditioning Mine Air for Shallow Underground Mines
A. Nikolaev, T. Miftakhov and E. Nikolaeva

- 01023 Knowledge Assessment Software in Mining Specialist Training
V. Lebedev and O. Puhova
- 01024 Modeling of Three Flat Coal Seams Strata Developing at Open Pit Mining
T. Gvozdkova, S. Markov, N. Demirel and S. Anyona
- 01025 Parameters of Transportation of Tailings of Metals Lixiviating
V. Golik and Y. Dmitrak
- 01026 Ecological and Economic Prerequisites for the Extraction of Solid Minerals from the Bottom of the Arctic Seas
A. Myaskov and A. Gonchar
- 01027 Efficiency of Low-Profile External Dumping at Open Pit Coal Mining in Kemerovo Region
A. Selyukov, V. Ermolaev and I. Kostinez
- 01028 Numerical Simulation of Aerogasdynamics Processes in a Longwall Panel for Estimation of Spontaneous Combustion Hazards
S. Meshkov and A. Sidorenko
- 01029 The Development of Environmentally Friendly Technologies of Using Coals and Products of Their Enrichment in the Form of Coal Water Slurries
V. Murko and V. Hamalainen
- 01030 Assessing the Effects of Underground Mining Activities on High-Voltage Overhead Power Lines
V. Gusev, A. Zhuravlyov and E. Maliukhina
- 01031 Using of Wide Stopes in Coalless Zones Mined by Shovels and Backhoes
V. Kolesnikov, O. Litvin, J. Janočko and A. Efremenkov
- 01032 Intelligent Mining Engineering Systems in the Structure of Industry 4.0
M. Rylnikova, D. Radchenko and D. Klebanov
- 01033 Causes of Low Efficiency of Combined Ventilation System in Coal Mines in Resolving the Problem of Air Leaks (Inflows) Between Levels and Surface
V. Popov, Y. Filatov, Hee Lee and A. Golik
- 01034 Problem of Methane-Air Mixture Explosions in Working Faces of Coal Mines at Mining Intensification and Ways of its Solution
S. Novoselov, V. Popov, Y. Filatov, Hee Lee and A. Golik
- 01035 Coal Squeezing-Out, its Description and Conditions of Development
S. Kostyuk, A. Gegreen, V. Meljnik and M. Lupeey

Environment Problems in Mining Regions

- 02001 Energy and Resource-Saving Sources of Energy in Small Power Engineering of Siberia
M. Baranova
- 02002 The Increase of Power Efficiency of Underground Coal Mining by the Forecasting of Electric Power Consumption
V. Efremenko, R. Belyaevsky and E. Skrebneva
- 02003 Scientific Background for Processing of Aluminum Waste
O. Kononchuk, A. Alekseev, O. Zubkova and V. Udovitsky
- 02004 Research of Environmental and Economic Interactions of Coke And By-Product Process
V. Mikhailov, T. Kiseleva, S. Bugrova, A. Muromtseva and Y. Mikhailova
- 02005 Coal Producer's Rubber Waste Processing Development
E. Makarevich, A. Papin, A. Nevedrov, T. Cherkasova and A. Ignatova
- 02006 Enhancement of Operating Efficiency of the Central Coal-Preparation Plant of "MMK –UGOL" Ltd. Under Current Conditions
M. Basarygin
- 02007 Diagnostics of Oil Pollution Zones by Electro-Physical Method
S. Prostov and E. Shabanov
- 02008 Ensuring the Environmental and Industrial Safety in Solid Mineral Deposit Surface Mining
K. Trubetskoy, M. Rylnikova and E. Esina
- 02009 Rare and Rare-Earth Metals in Coal Processing Waste
T. Cherkasova, E. Cherkasova, A. Tikhomirova, A. Bobrovnikova and I. Goryunova
- 02010 Effective Processing of the Iron Ores
V. Kuskov, Y. Kuskova and V. Udovitsky
- 02011 Influence of Coal Industry Enterprises on Biodiversity (on the Example of Formicidae)
S. Blinova and T. Dobrydina
- 02012 Land Resource Management as the Ground for Mining Area Sustainable Development
A. Solovitskiy, O. Brel, N. Nikulin, E. Nastavko and T. Meser
- 02013 Adaptive Adjustment in Taraxacum Officinale Wigg. in the Conditions of Overburden Dump
O. Legoshchina, I. Egorova and O. Neverova

02014 Formation of Mesoherpetobionts Communities on a Reclaimed Coal Open Pit Dump

S. Luzyanin and N. Eremeeva

02015 Resource-Saving Cleaning Technologies for Power Plant Waste-Water Cooling Ponds

L. Zakonnova, I. Nikishkin and A. Rostovzev

02016 Innovative Production of Polyvinylchloride on the Basis of Vertical Integration of Business and Cluster Organisation

I. Kudryashova, N. Zakharova and E. Kharlampenkov

02017 The Environmental Impacts of the Coal Industry

S. Burtsev, V. Efimov and T. Korchagina

02018 Stimulation of the Methane Production with the Use of Changing of the Rock Massif Physical Conditions

M. Baev, V. Khyamyalyaynen and A. Shevtsov

02019 Increasing the Reliability of the Work of Artificial Filtering Arrays for the Purification of Quarry Waste Water

M. Tyulenev, Y. Lesin, O. Litvin, E. Maliukhina and A. Abay

02020 Organizational-Legal and Technological Aspects of Ensuring Environmental Safety of Mining Enterprises: Perspective Analysis in the Context of the General Enhancement of Environmental Problem

E. Vorontsova, A. Vorontsov and Y. Drozdenko

02021 Belt Aligning Revisited

V. Yurchenko

02022 Spectral Study of Modified Humic Acids from Lignite

S. Zherebtsov, N. Malysenko, L. Bryukhovetskaya and Z. Ismagilov

Innovations in Mining Machinery

03001 Substantiation of the Necessity for Design of Geohod Control System

V. Aksenov, I. Chicherin, I. Kostinez, A. Kazantsev and A. Efremenkov

03002 Dependence of Reliability and Resource of the Elements of the Design of Quarry Automatics with the Degrees of their Downloads

D. Stenin and N. Stenina

03003 Functional Quality Criterion of Rock Handling Mechanization at Open-pit Mines

Y. Voronov and A. Voronov

- 03004 Definition of Static Voltage Characteristics of the Motor Load for the Purpose of Increase in Energy Efficiency of Coal Mines of Kuzbass
F. Nepsha and V. Efremenko
- 03005 Disk Rock Cutting Tool for the Implementation of Resource-Saving Technologies of Mining of Solid Minerals
L. Mametyev, A. Khoreshok, A. Tsekhin and A. Borisov
- 03006 Technical Diagnostics of Ventilation Units for Energy Efficiency and Safety of Operation
E. Kuzin, V. Shahmanov and D. Dubinkin
- 03007 Load Cases Relevant for Proof of Competence of Fast Running Hoists
S. Vöth
- 03008 The Influence of Parameters on the Generatrix of the Helicoid Form Guide of Geokhod Bar Working Body
V. Aksenov, V. Sadovets and D. Pashkov
- 03009 Application of Mathematical and Three-Dimensional Computer Modeling Tools in the Planning of Processes of Fuel and Energy Complexes
O. Aksenova, E. Nikolaeva and M. Cehlár
- 03010 Justification of the Shape of a Non-Circular Cross-Section for Drilling With a Roller Cutter
G. Buyalich and M. Husnutdinov
- 03011 Improving the Repair Planning System for Mining Equipment on the Basis of Non-destructive Evaluation Data
M. Drygin and N. Kuryshkin
- 03012 The Raising Influence of Information Technologies on Professional Training in the Sphere of Automated Driving When Transporting Mined Rock
A. Kosolapov and S. Krysin
- 03013 Estimation of Energy Efficiency of Means of Transport According to the Results of Technical Diagnostics
A. Shalkov and M. Mamaeva
- 03014 Innovations of Engineering Company and Competitiveness in the Mining Equipment Market
V. Pogrebnoi, L. Samorodova, L. Shut'ko, Y. Yakunina and O. Lyubimov
- 03015 Increasing the Technical Level of Mining Haul Trucks
Y. Voronov, A. Voronov, S. Grishin and A. Bujankin
- 03016 Forecasting of a Thermal Condition of Pneumatic Tires of Dump Trucks
A. Kvasova, B. Gerike, E. Murko and D. Skudarnov

03017 Perfection of Methods of Mathematical Analysis for Increasing the Completeness of Subsoil Development

M. Fokina

03018 Factors Determining the Size of Sealing Clearance in Hydraulic Legs of Powered Supports

G. Buyalich, K. Buyalich and M. Byakov

Mining Regions' Sustainable Development

04001 Individual Learning Route as a Way of Highly Qualified Specialists Training for Extraction of Solid Commercial Minerals Enterprises

E. Oschepkova, I. Vasinskaya and I. Sockoluck

04002 Sustainable Development vs. Post-Industrial Transformation: Possibilities for Russia

S. Zhironkin, M. Gasanov, G. Barysheva, E. Gasanov, O. Zhironkina and G. Kayachev

04003 Neo-Industrial and Sustainable Development of Russia as Mineral Resources Exploiting Country

M. Prokudina, O. Zhironkina, O. Kalinina, M. Gasanov, F. Agafonov

04004 Viral Management as a New Type of Enterprise Management in Coal Industry

O. Garafonova, S. Grigashkina and A. Zhosan

04005 The Regional-Matrix Approach to the Training of Highly Qualified Personnel for the Sustainable Development of the Mining Region

E. Zhernov and E. Nehoda

04006 Improvement of the System of Training of Specialists by University for Coal Mining Enterprises

V. Mikhailchenko and I. Seredkina

04007 The Concept of Resource Use Efficiency as a Theoretical Basis for Promising Coal Mining Technologies

V. Mikhailchenko

04008 Ideological Paradigms and Their Impact on Environmental Problems Solutions in Coal Mining Regions

V. Zolotukhin, N. Zolotukhina, M. Yazevich, A. Rodionov and Marina Kozyreva

04009 The Prospects of Accounting at Mining Enterprises as a Factor of Ensuring their Sustainable Development

T. Tyuleneva

04010 Tools of Realization of Social Responsibility of Industrial Business for Sustainable Socio-economic Development of Mining Region's Rural Territory

T. Jurzina, N. Egorova, N. Zaruba and P. Kosinskij

- 04011 Score Mining Rents in Terms of Investment Attractiveness of Peat Mining
G. Alexandrov and A. Yablonev
- 04012 Mastering Foreign Language Competence of Ecology and Environment Managers for Mining Industry of Kuzbass
O. Greenwald, R. Islamov and T. Sergeychick
- 04013 NBIC-Convergence as a Paradigm Platform of Sustainable Development
E. Dotsenko
- 04014 Sustainable Development Strategy for Russian Mineral Resources Extracting Economy
E. Dotsenko, N. Ezdina, A. Prilepskaya and K. Pivnyk
- 04015 Humanity and Environment Co-influence in the Shadow of Technological Convergence
N. Ezdina
- 04016 Modern Trends of Additional Professional Education Development for Mineral Resource Extracting
O. Borisova, V. Frolova and E. Merzlikina
- 04017 Corporate Social and Ecological Responsibility of Russian Coal Mining Companies
N. Ravochkin, V. Shchennikov and V. Syrov
- 04018 Diversification of the Higher Mining Education Financing in Globalization Era
V. Frolova, O. Dolina and T. Shpil'kina
- 04019 Andragogical Model in Language Training of Mining Specialists
E. Bondareva, G. Chistyakova, Y. Kleshevskyi, S. Sergeev and A. Stepanov
- 04020 Improving Occupational and Industrial Safety Management System at Coal Mining Enterprises
S. Smagina, O. Kadnikova, K. Demidenko, G. Chistyakova and A. Rolgayzer
- 04021 Education within Sustainable Development: Critical Thinking Formation on ESL Class
I. Pevneva, O. Gavrishina, A. Smirnova, E. Rozhneva and N. Yakimova
- 04022 Some Diversification Factors of Old Industrial Regions' Economy and Transition to the Innovative Development
O. Tabashnikova
- 04023 Key Trends in Institutional Changes Under Sustainable Development
O. Karpova, I. Pevneva, I. Dymova, T. Kostina and S. Li
- 04024 Integration of MOOCs in Advanced Mining Training Programmes

I. Saveleva, O. Greenwald, S. Kolomiets and E. Medvedeva

04025 Innovative Technological Development of Russian Mining Regions (on Example of Kemerovo Region)

E. Shavina and O. Kalenov

04026 Age-Sex Structure of the Population and Demographic Processes in Environmentally Challenged Mining Region (on the example of Kemerovo region)

T. Leshukov, O. Brel, A. Zaytseva, Ph. Kaizer and K Makarov

04027 The Distribution of the Informative Intensity of the Text in Terms of its Structure (On Materials of the English Texts in the Mining Sphere)

L. Znikina and E. Rozhneva

04028 Training of Engineering Personnel for the Innovative Coal Industry: Problems and Ways of Solution

N. Zaruba, T. Fraltsova and T. Snegireva

04029 Innovative Model of Practice-Oriented Training of Employees of the Town-Forming Enterprise in the Mining Region (by the Example of JSC "SUEK-Kuzbass")

S. Kulay and G. Kayachev

04030 Improvement and Development of the Motivation System in the Occupational and Industrial Safety Field

A. Pavlov and D. Gavrilov

The sustainable development of mining regions requires synchronous impetus of innovations in mineral resources extracting and processing, environment protection technologies, mining machinery and social-and-economic activities. The whole industrial complex of the region including subsoil use, modernization of mining equipment and the development of human capital should become a platform for sustainable development. The aim of The 11nd International Innovative Mining Symposium (Devoted to Russian Federation Year of Environment) is to create a workshop for international discussion of urgent issues of resource sector's environment-friendly development worldwide by specialists, experts and researchers. The leading role in this discussion belongs to the mineral resource universities – the centers of innovative development of the mining regions.

ISBN: 978-2-7598-9026-2



www.e3s-conferences.org

Statement of Peer review

In submitting conference proceedings to E3S Web of Conferences, I certify to the Publisher that I adhere to the **Policy on Publishing Integrity** of the journal in order to safeguard good scientific practice in publishing.

1. All articles have been subjected to peer review administered by the proceedings editors.
2. Reviews have been conducted by expert referees, who have been requested to provide unbiased and constructive comments aimed, whenever possible, at improving the work.
3. Proceedings editors have taken all reasonable steps to ensure the quality of the materials they publish and their decision to accept or reject a paper for publication has been based only on the merits of the work and the relevance to the journal.

Title, date and place of the conference

11nd International Innovative Mining Symposium (Devoted to Russian Federation Year of Environment), 20-22 November 2017, Kemerovo, Russian Federation

Proceedings editor(s):

Maxim Tyulenev, PhD, Kuzbass State Technical University
Sergey Zhironkin, DSc, National Research Tomsk Polytechnic University
Alexey Khoreshok, DSc, Kuzbass State Technical University
Stefan Voth, Dr.-Ing, TFH Georg Agricola
Michal Cehlar, PhD, Technical University of Kosice
Demirel Nuray, PhD, Middle East Technical University, Turkey

Date and editor's signature

Date

17.09.2017